

# Introduction to Wireless Communications and Networks

## Outline

Overview of a Communication System

Digital vs. Analog Communications

Examples of Wireless Communication Systems

Why Wireless is Different ?

Wireless System Architecture



Multiple Access Techniques

Evolution of Cellular Networks (1G ~ 3G)

Wireless Local Area Networks (WLANs), Bluetooth and  
Personal Area Networks (PANs)

Ad hoc networks

Topics to be covered in the course

# Components of a Communication System (1)

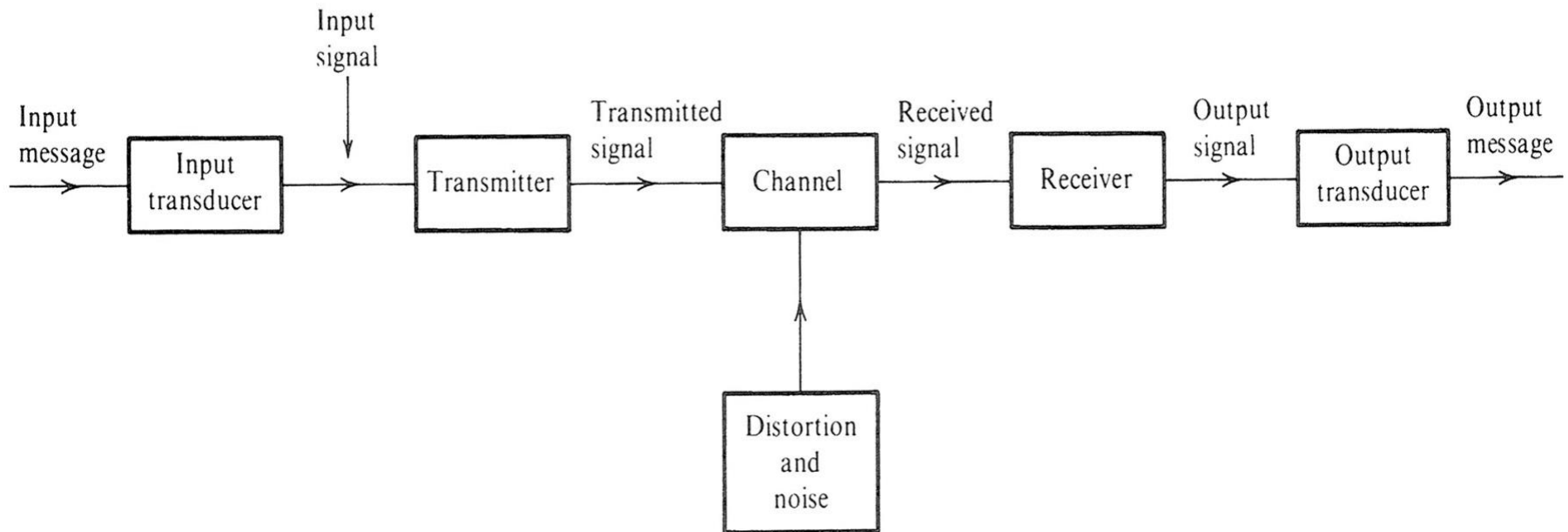

Figure 1: Communication Systems

# Components of a Communication System (2)

- ④ The **source** originates a message, which could be a human voice, a television picture or data. The source is converted by an **input transducer** into an electrical waveform referred to as the baseband signal or message signal.
- ④ The **transmitter** modifies the baseband signal for efficient transmission. The transmitter generally consists of one or more of the following subsystems: a pre-emphasizer, a sampler, a quantizer, a coder and a modulator.
- ④ The **channel** is a medium through which the transmitter output is sent, which could be a wire, a coaxial cable, an optical fiber, or a radio link, etc. Based on the channel type, modern communication systems are divided into two categories: **wireline communication** systems and **wireless communication** systems.

## Components of a Communication System (3)

- ④ The **receiver** reprocessed the signal received from the channel by undoing the signal modifications made at the transmitter and the channel. The task of the receiver is to extract the message from the distorted and noisy signal at the channel output. The receiver may consist of a demodulator, a decoder, a filter, and a de-emphasizer.
- ④ The receiver output is fed to the **output transducer**, which converts the electrical signal to its original form.
- ④ Transmitters and receivers are carefully designed to overcome the distortion and noise. The Goal of Physical layer Communication System is to **transmit information accurately and efficiently** (power and spectrum).

# Digital vs. Analog Communications (1)

## ④ Analog and Digital Signals

④ Messages are digital or analog.

④ Digital messages are constructed with a finite number of symbols. For example, a text file is a digital message constructed from 50 symbols, consists of 26 letters, 10 numbers, a space and several punctuation marks. Similarly, a Morse-coded telegraph is a binary message, implying only two symbols – mark and space.

④ Analog messages are characterized by data whose values vary over a continuous range. For example, a speech waveform has amplitudes that vary over a continuous range.

A picture is also an analog message.

## Noise immunity of digital signals

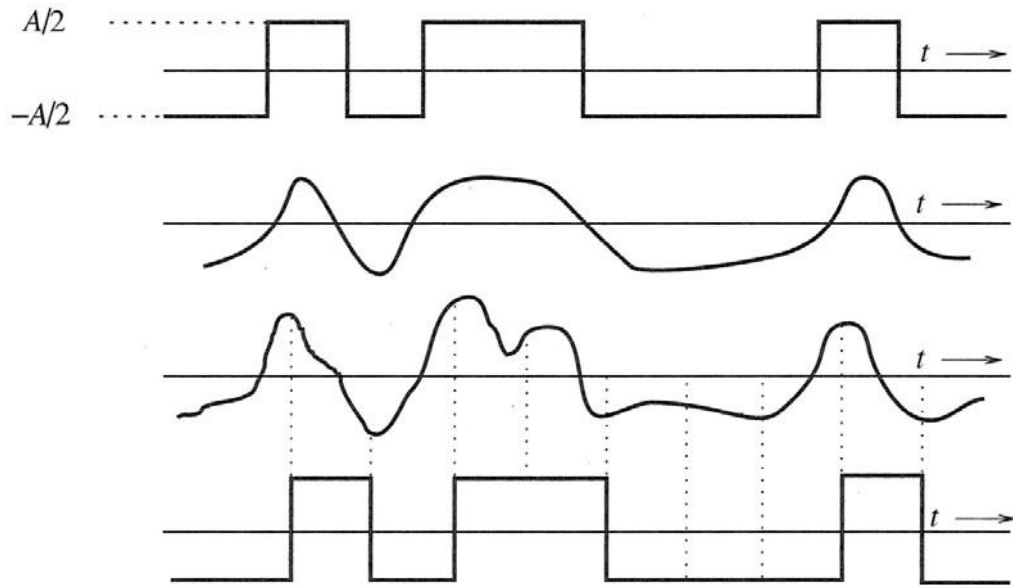

**Figure 1.3** (a) Transmitted signal. (b) Received distorted signal (without noise). (c) Received distorted signal (with noise). (d) Regenerated signal (delayed).

## Digital vs. Analog Communications (2)

- ④ **Noise immunity of digital signals** – digital data can be recovered without any error as long as the distortion and noise are within limits. On the other hand, for an analog message, even a slight distortion or interference in the waveform will cause an error in the received signal.
- ④ **Regenerative repeaters**—Based on this “noise immunity”, when transporting a bit stream over a long distance, regenerative repeaters or repeater stations are placed along the path of a digital system at distances short enough to ensure that noise and distortion remain within a limit. The viability of regenerative repeaters is the main reason for the superiority of digital systems over analog ones.
- ④ **Every possible communication can be carried on with a minimum of two symbols**, i.e., by using a proper binary sequence. In the last 20 years, digital communication gradually replace its analog competitors, and the revolution is now nearly complete.



# Interface of Analog and Digital Systems

## -- A/D and D/A Conversion

- ④ **Sampling Theorem** A meeting ground exists for analog and digital signals: conversion of analog signals to digital signals. The backbone that supports the interface is Shannon's Sampling Theorem, which states that if the highest frequency in the signal spectrum is  $B$  (in hertz), then the signal can be recovered from its samples, taken at a rate not less than  $2B$  samples per second.
- ④ **Quantization** each sample is approximated, or round off to the nearest quantized level, the information is thus digitalized. The quantized signal is an approximation of the original one. We can improve the accuracy of the quantized signal to any desired degree by increasing the number of levels.
- ④ **Coding**
- ④ **Source coding** Convert the quantized signal into binary sequences.
- ④ **Channel coding** Introduce redundancy in a controlled manner to overcome the effects of noise and interferences.

- ④ **Mapping** Map binary sequence into symbols.
- ④ **Transmission** Symbols are applied to a transmitter filter, which produces a continuous signal for transmission over a continuous channel.

## Examples of Wireless Communication Systems

- ④ Codeless telephones --- use radio to connect a portable handset to a dedicated base station over a distance of a few tens of meters.
- ④ Paging systems --- Communication systems that broadcast a page from every base station in the network and send brief messages to a subscriber.
- ④ Cellular telephone systems --- provide a wireless connection to the PSTN (Public Switched Telephone Network) for any user location within the radio range of a system.
- ④ Garage car opener
- ④ Remote controllers for home entertainment equipment
- ④ Hand-held walkie-talkies

- ④ Wireless keyboard and mouse
- ④ Wireless Lan router and adapter
- ④ .....

## Wireless Vs. Wireline Communications

### ----- Challenges in Wireless Communication Systems

#### ④ **Wireless channel**

- ④ Have time varying and multipath propagation properties.
- ④ Communicate over a medium significantly less reliable than wired physical layer.
- ④ Are unprotected from outside signals and interceptions. Multiuser interference (MUI) is a significant problem in wireless communications.
- ④ Has neither absolute nor readily observable boundaries outside of which stations are known to be unable to receive network frames.

## ④ **User Mobility**

- ④ Destination address does not equal to a fixed destination location.
- ④ Power management --- performance, interference level and power consumption.
- ④ Hand-off --- A mobile switches its serving base station while moving from cell to cell.
- ④ Location management --- tracks the user's movement, support users roaming delivers calls to the user at its current location.

# Trends on Wireless Communications

4.50	6.29	0.0		
4.52	6.31	0.01		
4.55	6.28	0.00	5.67	
4.49	6.28	0.01	5.5	
4.52	6.31	0.02	5.67	
4.55	6.28	0.00	5.67	
4.49	6.28	0.01	5.5	
4.52	6.31	0.02	5.67	

- ④ **Rapid growth** In the last few decades, new and cheaper wireless services are emerging continuously, due to advances in:
  - ④ Digital signal processing
  - ④ Digital and RF circuit fabrication
  - ④ Large scale circuit integration
  - ④ Digital switching techniques -> large scale deployment of radio communication networks
- ④ **Convergence of wireless and Internet ----- Broadband communications**
  - ④ 3G cellular and PCS networks
  - ④ WLAN networks
  - ④ Ad-hoc Networks (military)

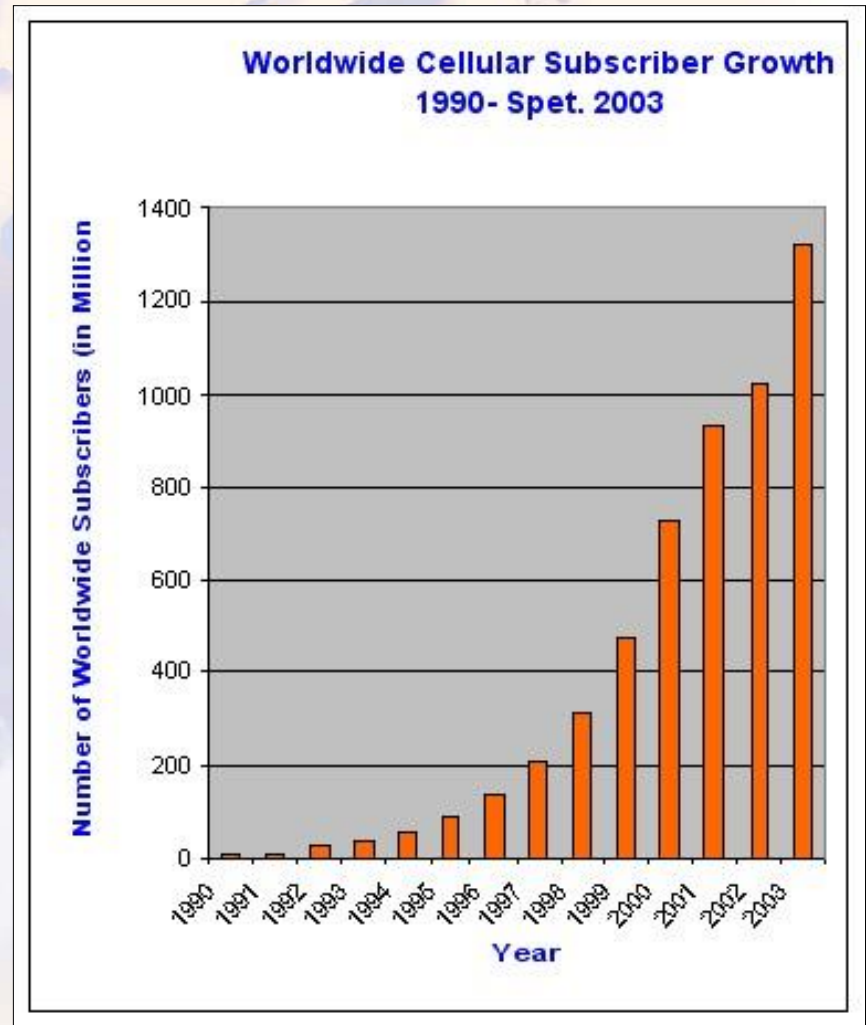

# Cellular System Architecture

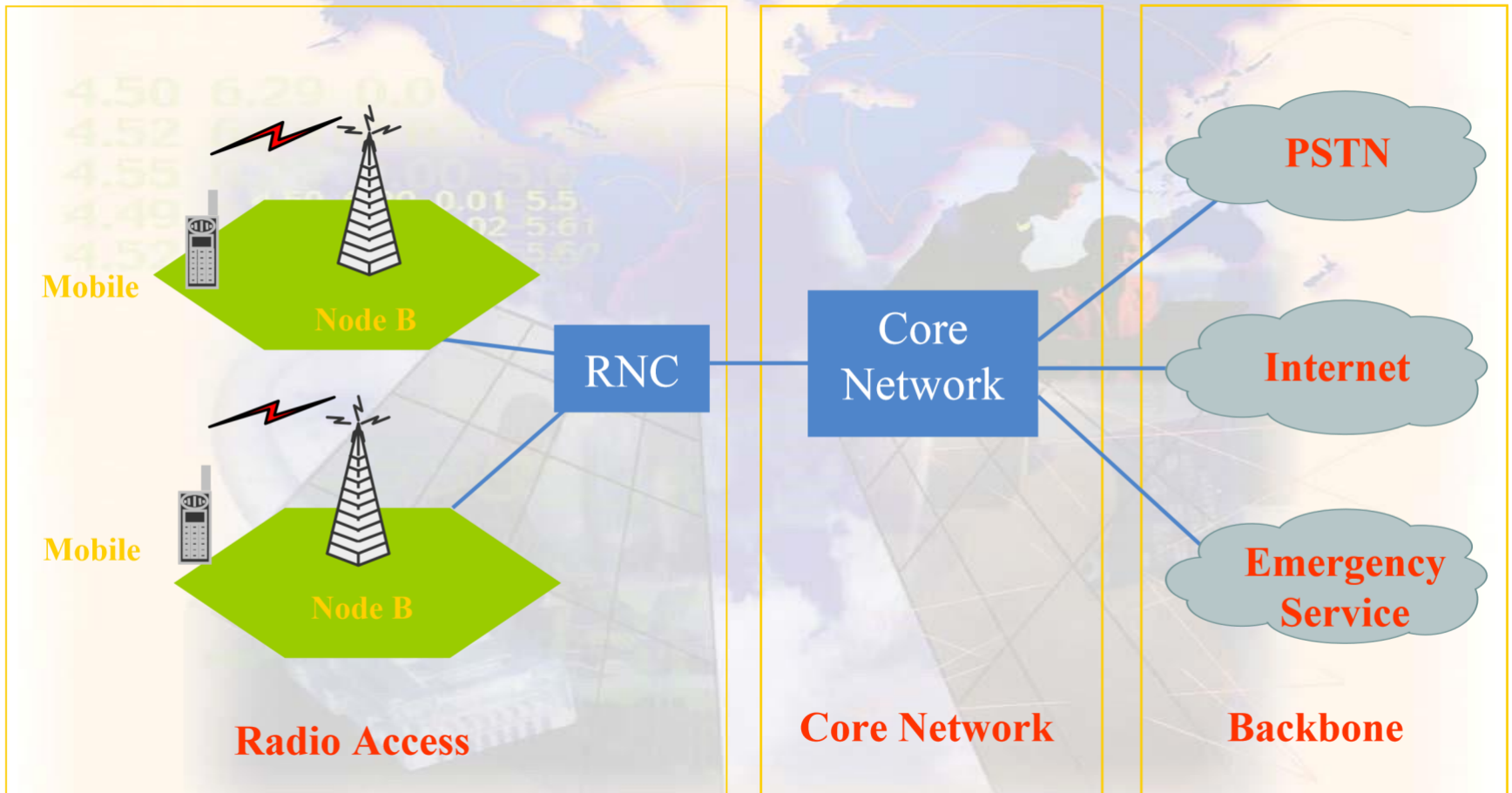

# Cellular System Architecture

- ④ **Radio Access:** RF related signal processing and radio resource management. Mobile => base station => BSC or RNC => MSC.
- ④ **Core Network:** Main part is MSC (mobile switching center), performs user authentication, admission control, traffic control, roaming, billing, network support and maintenance etc.
- ④ **Backbone networks:** Providing voice services (PSTN, Public Switched Telephone Network), data services (through Internet), and emergency services. Wireless networks need to be connected to backbone networks to extend its service capabilities and geographic coverage.



# Multiple Access Techniques

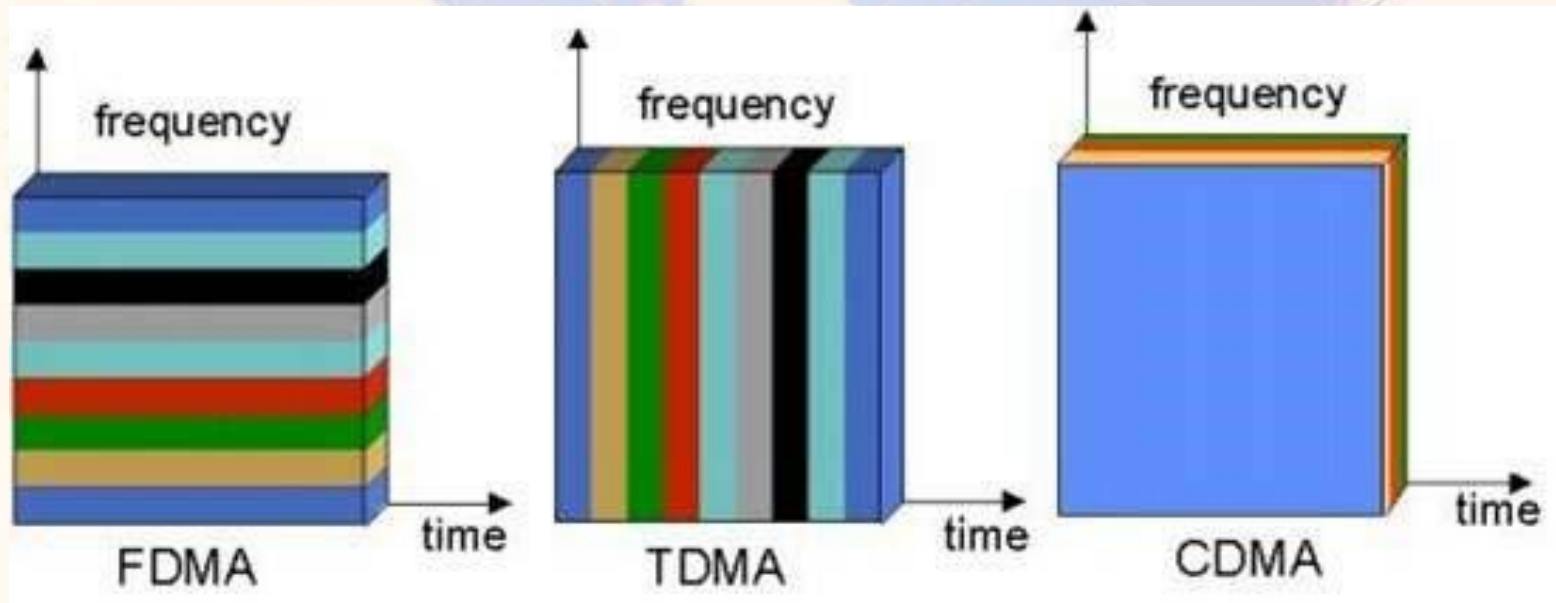

# Multiple Access Techniques

- ④ **FDMA** (Frequency Division Multiple Access) each user is allocated a unique frequency band or channel, no other user can share the same frequency band.

- ④ **TDMA** (Time Division Multiple Access) divides the radio spectrum into time slots, and in each slot, only one user is allowed to either transmit or receive.
- ④ **CDMA** (Code Division Multiple Access) each user is assigned a special code sequence (signature) to modulate its message signal, all users are allowed to transmit over the same channel simultaneously and asynchronously.
- ④ **SDMA** (Space Division Multiple Access) controls the radiated energy for each user in space. SDMA serves different users by using spot beam antennas.

## How a cellular telephone call is made?

- ④ **Receiving a call**
- ④ Turn on a cellular phone
- ④ The cellular phone scan the control channels to determine the one with the strongest signal, it then monitors the signal drops below a usable level. At his point, it starts to search of strongest base station again.

- ④ If a phone call is placed to a mobile user, the MSC dispatches the request to all the base stations in the system, the MIN (mobile identification number, i.e. the mobile's phone number) is broadcast as a paging message through the forward control channel.
- ④ The mobile receives the signal through the base station it monitors and responds by identifying itself through the reverse control channel.
- ④ The base station informs the MSC of the handshake.
- ④ The MSC instructs the base station to move the call to an unused voice channel within the cell.
- ④ The base station signals the mobile to change frequencies to the unused unused forward and reverse voice channel pair.
- ④ The base station instructs the mobile phone to ring, thereby to instruct the user to answer the phone.

## How a cellular phone call is made (continued)

- ④ **Initiating a call**
- ④ The mobile sends a call initiation request through the reverse control channel, with this the unit transmits its MIN, ESN (electronic serial number) and the phone number of the called party.

- ④ Base station receives the request and sends it to the MSC.
- ④ The MSC validates the request, making connection to the called party through PSTN.
- ④ The MSC instructs the base station and mobile user to move to an unused forward and reverse voice channel pair.

### ④ **Roaming**

- ④ All cellular systems provide a service called *roaming*. This allows subscribers to operate in service areas other than the one from which the service is subscribed.
- ④ The MSC issues a global command every several minutes, asking all unregistered mobiles to report their subscription information.
- ④ Mobiles report back upon receiving the request.
- ④ If the mobile has roaming authorization for billing purpose, the MSC registers the subscriber as a *roamer*.

# Wireless System Evolution: Cellular Networks

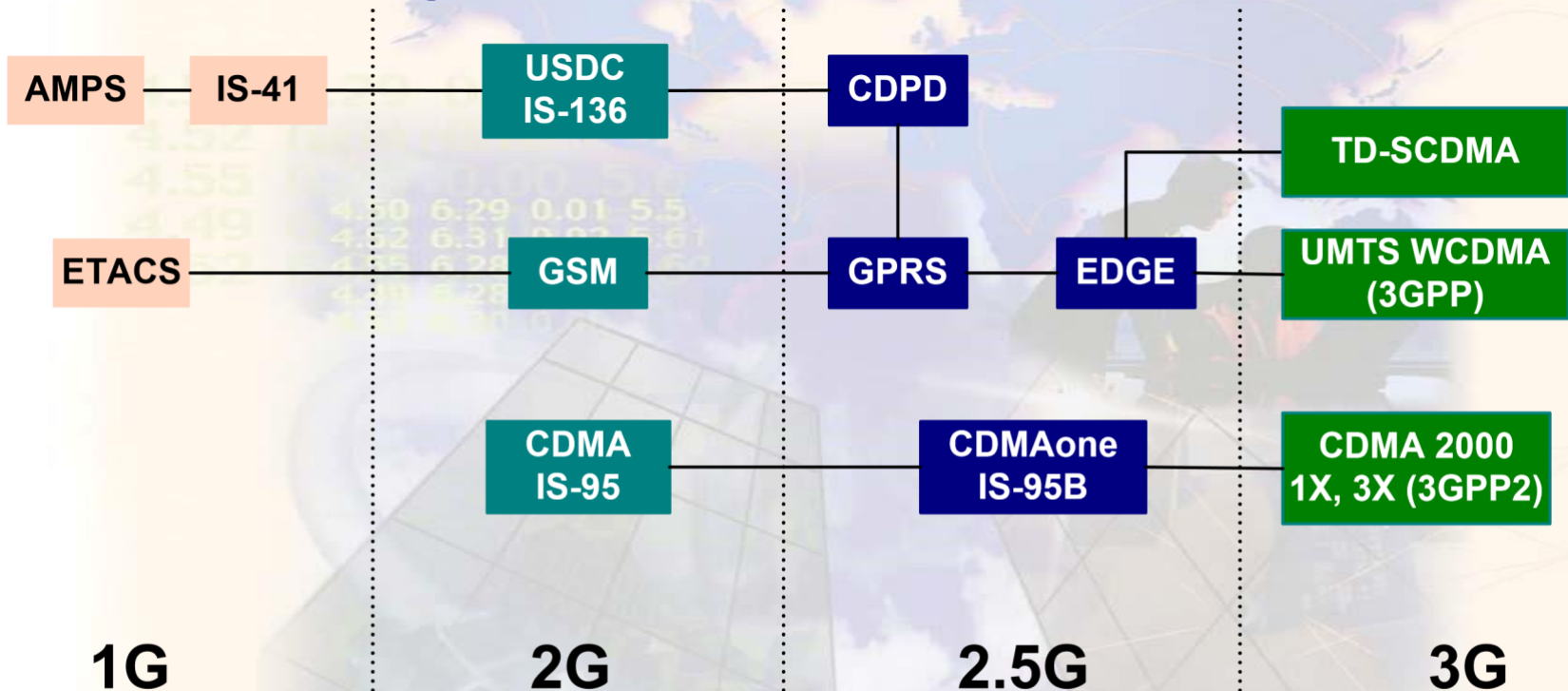

**AMPS** Advanced Mobile Phone System  
**ETACS** European Total Access Communication System

**GPRS** General Packet Radio Service  
**EDGE** Enhanced Data Rates for GSM Evolution

USDC United States Digital Cellular Global Systems for Mobile Packet Data UMTS Universal Mobile Telecommunications System GSM 3GPP 3<sup>rd</sup> Generation Partnership Project CDPD Cellular Digital Packet Data

## 1G Wireless Systems

- ④ Appeared in late 1970s and deployed in early 1980s.
- ④ All based on analog techniques, all used FDMA and FM modulation.
- ④ System capacity is low. Data rate: 8~10 kbps ④ Representative Standards:
- ④ **AMPS:** Advanced Mobile Phone System, developed by AT&T Bell Labs in late 1970s. First deployed in 1983. The first AMPS system **used large cells and omni-directional base station antennas, therefore, the number of users that can be supported was quite limited.** AMPS is used all over the world and is esp. popular in US, South America, China and Australia.

- ④ **ETACS:** European Total Access Communication Systems. Almost identical to AMPS except that the channel bandwidth is scaled to 25kHz instead of 30 kHz as in AMPS.

## 2G Wireless Systems: Characteristics

- ④ Deployed in mid 1990s, 2G wireless systems all use digital voice coding and digital modulation.
- ④ Can provide advanced call capabilities and at least a 3times increase in overall system capacity.
- ④ Was designed before the widespread of the Internet, mainly supported voice-centric services and limited data-service, like short messages, FAX, etc.
- ④ Data rate: on the order of 10 kbps

## 2G Wireless Systems: Representative Standards

- ④ **GSM** (Global Systems for Mobile communications)
  - ④ A TDMA system, serves as the pan-European cellular service, provides a wide range of network service, including phone service, FAX, short message service. Support **24.7kbps** data rate.
- ④ **USDC IS-136** (United States Digital Cellular)
  - ④ A TDMA system which is compatible with AMPS, it supports more users (6 times) with improved performance. It shares the same frequencies, frequency reuse plan and base stations as AMPS. Provides access to VPN, supports short messages. Support **48.6kbps** data rate.
- ④ **IS-95** (United States Digital Cellular Standard )
  - ④ A CDMA standard also designed to be compatible with AMPS through using of CDMA/AMPS dual mode phones and base stations. Capacity is 8~10 times that of AMPS. Support **14.4kbps** data rate.



# 2.5G Wireless System

Compared to 2G systems, 2.5G systems enables high speed data communications, provides continuous connection to internet.

- ④ **CDPD** (Cellular Digital Packet Data), a data service for 1st and 2nd generation US cellular systems without additional bandwidth requirement, packet channels are dynamically assigned to idle voice channels. Support **48.6kbps** data rate as in IS-136.
- ④ **GPRS** (General Packet Radio Service), based on GSM by allowing multiple slots of a GSM radio channel be dedicated to an individual user, promises data rate from **56 kbps to 114kbps**-- continuous connection to the Internet for mobile phone and computer users, easy access to VPN (Virtual Private Network).
- ④ **EDGE** (Enhanced Data Rates for GSM Evolution), providing **384kbps** rate by using improved modulation (8-PSK instead of GMSK in GSM) and relaxed error control. Also referred to as EGPRS.
- ④ **CDMA one (IS-95B)**: Providing high speed data access on a common CDMA radio channel

by dedicating multiple orthogonal user channels for specific users or specific purposes. Support 115.2kbps.

## 3G Wireless Systems: Features

- ④ Features:
- ④ **High transmission rate and the support of multimedia services.**
- ④ Multiple-megabit internet services, and simultaneous voice and data access with multiple parties at the same time using a single mobile handset.
- ④ Data rate: around 2Mbps. Bandwidth: in the order of MHz
- ④ Seamless global roaming: wireless access from anywhere on the earth. Obviously, it will include the satellite networks.
- ④ 3GPP and 3GPP2

- ④ Worldwide standardization organizations established to gather global expertise, participated by almost all the big companies.
- ④ 3GPP: based on backward compatibility to GSM, IS-136, GPRS, EDGE etc.
- ④ 3GPP2: based on backward compatibility to IS-95, and CDMAone.

## 3G Wireless Systems: Challenges

- ④ **Impact of high transmission rate --- frequency selective fading**
  - ④ High transmission rate implies that the signal bandwidth is much wider than the coherence bandwidth of the channel, different frequency components in the signal will experience different fading characteristic.
  - ④ **Solution:** Modulate each signal components onto a different subcarrier and send them over the channel in parallel, so that each component will experience flat fading. => multicarrier systems.

## ④ System capacity and user mobility

- ④ Enlarged capacity and higher transmission rate requires more efficient deployment of the available bandwidth, which implies that the system needs to be reused more often.
- ④ Higher degree of frequency reuse implies more complex mobile management.
- ④ How to increase spectrum efficiency is the ultimate goal of communication research.

## 3G Wireless Systems: Representative Standards

- ④ **3GPP UMTS** (Universal Mobile Telecommunications System) A wideband CDMA (5MHz) standard based on the network fundamentals of GSM/EDGE, is designed to provide backward compatibility with GSM, IS136, GPRS and EDGE. Can support 2Mbps data rate. New RF equipment needed.

- ④ **3GPP2 CDMA 2000 3G 1X-3X** Use one (same bandwidth as IS-95) or three adjacent 1.25MHz channels (3-times bandwidth as that of IS-95) to provide instantaneous packet data access at 144kbps or 2Mbps. No additional RF equipment needed, changes are all made in software or baseband hardware.
- ④ **TD-SCDMA** (Time-division Synchronous CDMA) A standard proposed by CATT (China Academy and Telecommunications Technology) and Siemens Corporation. Relies on the existing GSM infrastructure and allows 3G data access by adding high data rate equipment (smart antennas) at each GSM station. Support up to 384kbps of packet data.

## Wireless Local Area Networks (WLANs) and Personal Area Networks (PANs, Bluetooth)

- ④ WLANs and PANs, provide **broadband telecommunications access in the local exchange**, driven by demand for broadband Internet access from business and homes due to the rapid growth of the Internet.

- ④ Provide high speed, high performance wireless connections between computers and the wireless access points, between laptops, between laptops and printers, scanners, video cameras and other electronics in local area or at home. => **Replace the cumbersome cords that connect devices to one another.**
- ④ Operate at low power and license free spectrum,
- ④ North America: IEEE 802.11x series, example: Wi-Fi.
- ④ Europe: HIPERLAN/2
- ④ Both IEEE 802.11a and HIPERLAN/2 support up to 54Mbps.
- ④ Use spread spectrum and OFDM technologies
- ④ Bluetooth: provides convenient and flexible low power short range wireless connections in personal area networks. First a manufacture, then extended to an open standard.

## Mobile Ad-Hoc Networks

- ④ Cellular networks have a fixed infrastructure, in which each mobile access the network and communicating to other mobiles through the base station.

That is, base station is the fixed infrastructure which performs centralized administration.

- ④ **Ad-Hoc networks are infrastructureless and have no fixed routers.** Each node (mobile) in the ad-hoc network can set up as and play the role of a base station in that it can transmit to and receive from other nodes in the network.
- ④ A node in an ad-hoc network to other nodes if they are within line-of-sight.
- ④ Non-line-of-sight-nodes are called *hidden nodes*. Communication between a pair of hidden nodes needs to hop over one or more intermediate nodes, in this sense, it is called **multihop networks**.
- ④ A system with a fixed infrastructure is basically a two-hop system.
- ④ Ad-hoc networks are highly dynamic and are generally used for military services.

# Conceptual Layers in a Wireless Network

- ④ **Physical layer** --- involves the actual signal transmission and reception over the propagation channel.
- ④ **Datalink Link layer** --- deals with signal at the output of the base station receiver, performs radio resource management, control, rate allocation, call admission, error control etc.
- ④ **Networks layer**: a protocol stack that includes handoff management, location management, traffic management and traffic control.
- ④ **Application layer**: communicating, distributed processes running in end systems (hosts), e.g.,

Application Layer power

Network Layer

Datalink Layer

Physical Layer



e-mail, Web, P2P file sharing, instant messaging

## Topics to be covered in this course

- ④ In this course, we will focus on cellular networks and will discuss the following topics:
- ④ Fundamentals of cellular communications
- ④ Characterization of the wireless channel
- ④ Transmitter techniques for mobile radio
- ④ Receiving techniques for fading dispersive channels
- ④ Multiple access techniques

- 
- ④ Mobile management in wireless networks
- ④ Wireless and wireline interworking